Centrifugal Fields

Author(s): J. W. Beams

Source: *The Scientific Monthly*, Vol. 66, No. 3 (Mar., 1948), pp. 255-258

Published by: American Association for the Advancement of Science

Stable URL: <https://www.jstor.org/stable/19287>

Accessed: 05-12-2018 19:56 UTC

JSTOR is a not-for-profit service that helps scholars, researchers, and students discover, use, and build upon a wide range of content in a trusted digital archive. We use information technology and tools to increase productivity and facilitate new forms of scholarship. For more information about JSTOR, please contact support@jstor.org.

Your use of the JSTOR archive indicates your acceptance of the Terms & Conditions of Use, available at <https://about.jstor.org/terms>



JSTOR

American Association for the Advancement of Science is collaborating with JSTOR to digitize, preserve and extend access to *The Scientific Monthly*

SCIENCE ON THE MARCH

CENTRIFUGAL FIELDS

THE generalization of Newton that every uncharged macroscopic piece of matter attracts every other uncharged macroscopic piece of matter in the universe is perhaps one of the most widely applicable laws of physics. Newton further showed that the amount of this attraction F between any two homogeneous spherical masses M_1 and M_2 a distance R apart is given by the simple relation

$$F = G \frac{M_1 M_2}{R^2}$$

where G is a universal constant. It will be observed from this relation of Newton that the gravitational force of the earth on any body near its surface is proportional to the mass of the body and to the mass of the earth. Since the force on a body is equal to the mass times the acceleration, every freely falling body near a given point on the earth's surface falls toward the earth with the same acceleration. This acceleration is called the acceleration of gravity g , and, although it varies slightly over the earth's surface, g is about 981 cm./sec². From various observations, astronomers have determined the gravitational acceleration on the surfaces of a number of astronomical bodies. For example, on the moon the gravitational acceleration is about one-sixth g , and that on the sun is almost 28 g . The most intense gravitational field so far found by the astronomers is 80,000 g on the surface of the star van Maanen. In other words, a mass weighing 100 pounds on the earth would weigh 4,000 tons on van Maanen if the respective weighings were carried out on spring balances. So far, man has not been able to change appreciably the gravitational acceleration of the earth or any of the astronomical bodies. He has, however, found ways of exerting forces and accelerations that are equivalent to gravitational accelerations and forces in the way matter is affected. For example,

such forces are experienced whenever a body is stopped or started or when it has its direction of motion changed. The forces resulting from the latter are, in practice, more akin to gravitational forces than any of the others, since they can be maintained constant for comparatively long periods of time.

If a mass M is whirled around an axis with an angular speed of N revolutions per second, the centrifugal force $F = 4 \pi^2 N^2 M r$ where r is the distance of M from the axis of rotation. If one takes a value of $r = 1$ meter, then the value of N required to give an acceleration equal to that of gravity g on the earth is only 0.5 rev./sec. Consequently, we see that it is possible to produce centrifugal forces up to values many times that of gravity; also, that they may be maintained over comparatively large regions or volumes. Perhaps the most valuable use so far found for centrifugal forces is the separation and purification of various materials. It is common knowledge that, if particles of various sizes and densities are allowed to settle out of a fluid, the larger, heavier particles settle out first, followed in turn by the smaller or less dense ones. Just over a century ago, Sir George Stokes showed that the velocity of fall or sedimentation of a spherical particle with a density d_p and radius a is given by the relation

$$v = \frac{2}{9n} (d_p - d_l) a^2 F$$

where d_l is the density of the liquid, n its coefficient of viscosity, and F the gravitational or centrifugal force. Consequently, the larger the value of the force F , the higher the settling speed. Upon examining the above equation, it might seem that from a practical standpoint all separation due to sedimentation could be carried out in the earth's field rather than in a centrifugal field, as the only advantage of the centrifugal field

would be in the shorter time of settling, and this could be compensated for by using larger settling tanks. However, this turns out not to be the case. It will be observed from the equation that the speed of settling decreases very rapidly as the size of the particle is decreased, and becomes extremely small when the particle approaches molecular dimensions. It is well known that all particles experience an ever-present Brownian motion, the amplitude of which increases as the size of the particle decreases and becomes quite large when the particle approaches molecular dimensions. This Brownian motion, or diffusion, always transports particles from regions of higher concentration to regions of lower concentration and hence opposes or stops sedimentation unless the centrifugal or gravitational force is large enough to overcome it. Consequently, in a great many important applications, the larger centrifugal forces, instead of gravity, must be used to produce any appreciable sedimentation, and as a result centrifuges or apparatus for producing centrifugal fields are common tools both in industry and in the laboratory.

As shown above, when the particle size reaches molecular dimensions, the centrifugal field must be made very large to produce sedimentation. However, with modern technique, sufficiently large centrifugal fields can be obtained to produce molecular sedimentation and, in fact, to separate the isotopes of the elements. Fortunately, most of the biologically important substances, such as viruses and hormones, are not deactivated by centrifugal fields large enough to concentrate them, so that the centrifuge method is a most effective way of purifying them. Since the velocity of sedimentation in a centrifugal field depends upon the size and mass of the particles being sedimented, the centrifuge may be used for determining both the mass and size of the particles.

If the particles are molecules, their mass and size also can be determined, and it turns out that the ultracentrifuge method, first developed by Svedberg and his colleagues about twenty-five years ago, is perhaps the most reliable way so far devised for measuring the molecular weights of proteins and

many other types of high molecular weight compounds. Also, if the particles are not of uniform size, the distribution of their masses and sizes can be obtained by centrifuging. It is interesting to note that the general centrifuge method has been used for obtaining molecular weights over the entire known molecular weight range, i.e., from hydrogen, the lightest known molecule, to certain biological compounds with molecular weights in

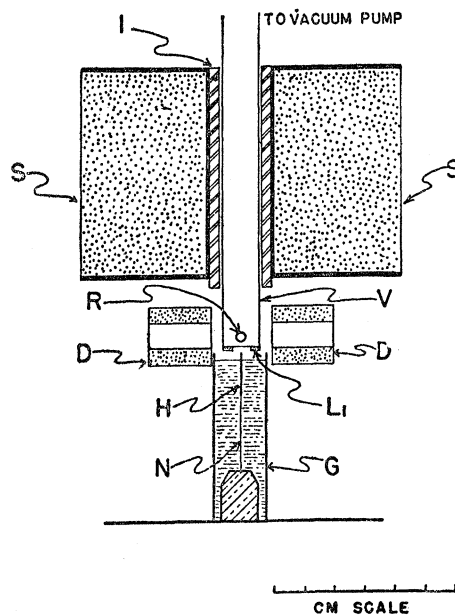

FIG. 1. ULTRACENTRIFUGE

SCHEMATIC DIAGRAM OF APPARATUS FOR PRODUCING ULTRAHIGH CENTRIFUGAL FIELDS. THE FUNCTION OF THE PARTS LETTERED IS GIVEN IN THE TEXT BELOW.

excess of twenty million molecular weight units.

In most of the experiments, where molecular sedimentation is obtained, the centrifugal field is in the range from 10^4 to 10^6 gravity which, except near the surface of a few distant stars, is much larger than any of the gravitational fields found so far in nature. Also, H. W. Beams, the Harveys, and others have found this same range of centrifugal fields most effective in their studies of the displacement of the components in biological cells. However, it has been found that the above maximum centrifugal fields of a million times gravity are far too small for

effective use in a number of different experiments, especially in physics. Consequently, a search for new ways of producing higher centrifugal fields has been undertaken at the University of Virginia, with the result that much higher centrifugal fields are available. For example, centrifugal fields of the order of half a billion gravity are now possible for laboratory use.

The technique of producing these high fields, although comparatively simple, will not be outlined in detail here, as it has been adequately described elsewhere. It might be of interest, however, to indicate briefly the general principles of the method. Figure 1 shows a schematic diagram of the apparatus. The rotor R is made of steel or other ferromagnetic material and is supported by the axial magnetic field of the solenoid S . It is well known that such a suspended rotor is stable as far as its lateral motion is concerned, but is not stable vertically if the current through the solenoid is steady. In order to give the rotor vertical stability, a small pickup coil L placed either below or above the rotor is made to regulate the electrical current through the solenoid S ; i.e., if the rotor R moves slightly upward, the current through S is decreased, whereas if it moves downward, the current through S is increased. Electrical damping also is introduced into the circuit so that, in practice, no vertical or horizontal oscillation of the rotor can be observed when it is viewed with a 30-power magnifier focused on scratches on the rotor surface. A small iron wire H , mounted in a glass tube filled with a liquid, assists in damping any horizontal motion of the rotor. The rotor is surrounded by a glass vacuum chamber V , which can be highly evacuated to reduce the gaseous friction. The rotor is spun by a rotating magnetic field produced by an alternating current through four coils D placed symmetrically around the rotor. The rotating magnetic field is used both to accelerate and decelerate the rotor. The speed of the rotor is measured by a photoelectric pickup arrangement.

It will be observed that the magnetic field that supports the rotor is symmetrical with respect to the axis of rotation. Consequently,

there are no appreciable eddy currents induced in the rotor that can resist its rotation, so that the only forces which substantially oppose its rotation arise from gaseous friction on the rotor surface. Since the air pressure in V can be made very small, the frictional drag can be made correspondingly small. For example, with a 1.59-mm. spherical rotor spinning 100,000 r.p.s., the driving current in the coils D was turned off and the rotor allowed to coast for a few hours while the deceleration was measured. It was found that the loss in speed was only about 0.1 percent per hour when the gaseous pressure surrounding the rotor was about 2×10^{-6} mm. of Hg. This value is in accord with that calculated from the kinetic theory of gases and in fact suggests that such spinning rotor arrangements can be used as absolute pressure manometers for measuring low gaseous pressure.

Test experiments were carried out with a series of small hardened-steel spherical rotors to determine the rotational speed necessary to make them explode. Table 1 shows some

TABLE 1

DIAMETER ROTOR	ROTOR SPEED	PERIPHERAL SPEED	CENTRIFUGAL ACCELERATION X GRAVITY	MAXIMUM CALCULATED STRESS
mm.	r.p.s.	cm./sec.		lb./in. ²
3.97	77,000	9.60×10^4	4.71×10^7	410,000
2.38	123,500	9.25×10^4	7.20×10^7	385,000
1.59	211,000	1.05×10^5	1.43×10^8	498,000
0.795	386,000	9.65×10^4	2.40×10^8	420,000
0.521	633,000	1.04×10^5	4.28×10^8	488,000

of the results obtained. It will be observed that the maximum peripheral speeds obtained were roughly constant (10^5 cm./sec.) for all the rotors. This should be expected from theory if the steel were perfectly elastic. On the other hand, the maximum centrifugal acceleration obtained was much larger with decreasing size of rotor and became 428 million times gravity for the 0.521-mm. rotor.

The very low frictional torque on the spinning rotor obtained in practice with the technique outlined makes it possible to obtain extremely constant rotor speed. In fact, it is

found that the rotors may be driven in synchronism with a piezoelectric crystal. This type of drive maintains the speed as constant as the frequency of the crystal-controlled driving circuit and should be better than one part in ten million. When mirror faces were ground on the magnetically suspended rotor, no appreciable friction was introduced, so that a rotating mirror of extremely constant speed was obtained. This development makes possible many experiments other than those requiring ultrahigh centrifugal fields. For example, the precision with which the speed of light can be determined may be increased by a factor of roughly 100 if the light path could be measured with the same precision as the rotational speed of the mirror. Incidentally, experiments are already in progress at Virginia for increasing the precision of measurement of the light path in comparable degree with that attained in measuring the speed of the rotating mirror by measuring the light path in terms of the wave length of a given spectral line. The method makes use of an interferometer somewhat similar to that used by Michelson many years ago for measuring the length of the

standard meter in terms of the wave length of light except that a photoelectron-multiplier cell and scaling circuit are used, instead of the human eye, for counting the fringes. The low frictional torque on the rotor also makes possible many other experiments such as the measurement of the pressure of light, etc.

From both theory and experiment (Table 1) it is evident that, as the diameter of the rotor is decreased, the maximum centrifugal force produced before rotor explosion increases. Also, with the technique of spinning the rotors discussed above, smaller rotors obviously may be spun than is indicated in Table 1. As a result, much higher centrifugal forces can be obtained. However, the successful study of the general effect of these high centrifugal fields on the properties of matters depends upon the development of methods of observing such changes in the fields. Consequently, considerable effort in the future must be directed to the study of these problems.

J. W. BEAMS

*Rouss Physical Laboratory
University of Virginia*

TENTATIVE ITINERARY*

FIRST ANNUAL INTERNATIONAL PHOTOGRAPHY-IN-SCIENCE SALON

THE BUHL PLANETARIUM AND INSTITUTE OF POPULAR SCIENCE Pittsburgh, Pennsylvania	January 10-24	GAMMA SIGMA EPSILON University of Florida Gainesville	May 13-June 1
CRANBROOK INSTITUTE OF SCI- ENCE Bloomfield Hills, Michigan	February 2-28	THE JOHN CRERER LIBRARY Chicago, Illinois	June 8-June 21
CLEVELAND HEALTH MUSEUM Cleveland, Ohio	March 8-29	AUBURN CAMERA CLUB Bureau of Animal Industry, U.S.D.A. Auburn, Alabama	June 28-July 12
<i>Science Illustrated</i> New York City	April 6-16	AMERICAN OSTEOPATHIC ASSO- CIATION ANNUAL CONVENTION Boston, Massachusetts	July 19-23
BROWN UNIVERSITY Providence, Rhode Island	April 22-May 6		

* Definite dates will be published later. Reservations for showing the 1948 Salon pictures may be made now.